

CRIMPFOX-RCI 6

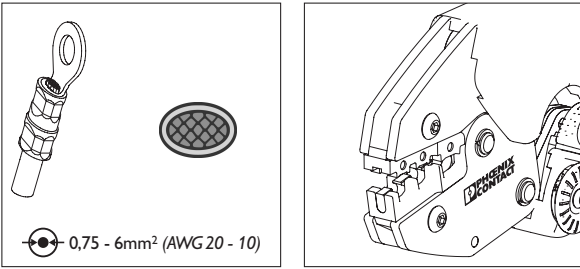

Professionelle Quetschzange zum Verarbeiten von isolierten Kabelschuhen.

Ausgestattet mit einer Zwangssperre (entriegelbar) bietet die Zange eine gleichbleibend hohe Qualitätsverpressung. Die ergonomisch geformten Griffe gewährleisten einen optimalen Halt und unterstützen ein ermüdungsarmes Arbeiten. Die Leitereinführung erfolgt seitlich. Drei farblich markierte Gesenkstationen dienen der präzisen Verarbeitung der entsprechenden Querschnittsbereiche.

Professional crimping pliers for processing non-insulated cable lugs.

Equipped with a forced lock (unlockable), the pliers provide a uniform high quality of crimping. The ergonomically formed handles ensure an optimum hold, thus making work less strenuous. The conductor entry is lateral. Three die stations marked in color serve for precise processing of the relevant cross-section ranges.

Zubehör/Accessories

CRIMPFOX-RCI 6/DIE Order No. 1212058

Ersatzgesenk für CRIMPFOX-RCI 6

Spare die for CRIMPFOX-RCI 6

CRIMPFOX /SPR-1 Order No. 1212069

Ersatz-Rückholfede

Replacement recuperating spring

CRIMPFOX

CRIMPFOX

PHENIX CONTACT
INSPIRING INNOVATIONS

CRIMPFOX-RCI 6 Quetschwerkzeug Crimping Tool

0,75 - 6mm²
(AWG 20 - 10)
Order No. 1212057



Operating instructions
 Bedienungsanleitung
 Mode d'emploi
 Istruzioni per l'uso
 Instrucciones de empleo
 Gebruiksaanwijzing
 Bruksanvisning
 Χειρισμός
 Utilização

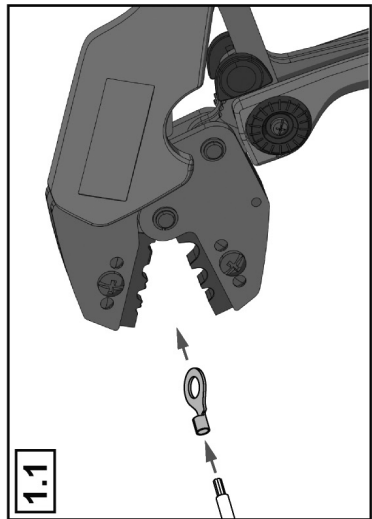

1.1

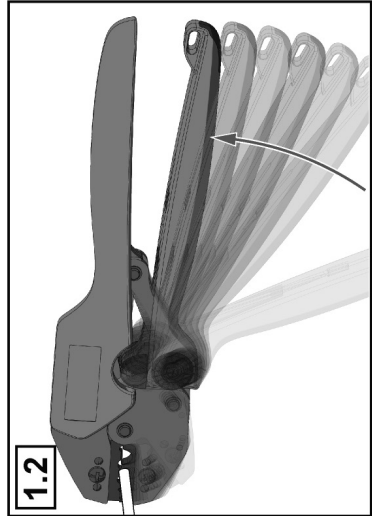

1.2

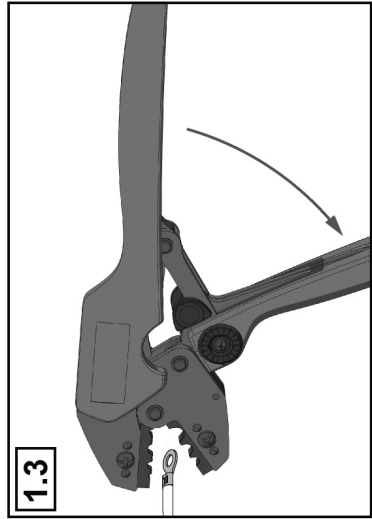

1.3

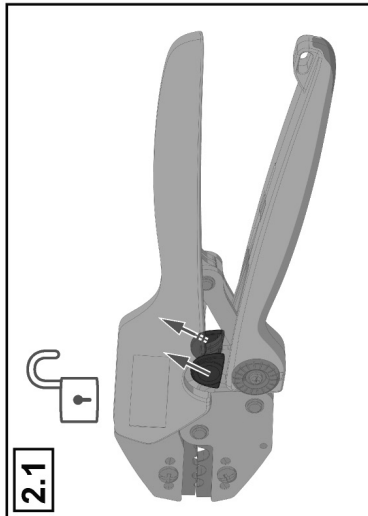

2.1



2.2

 	CAUTION VORSICHT ATTENTION	ATTENZIONE ATENCIÓN VOORZICHTIG	OBSERVER ΠΡΟΣΟΧΗ CUIDADO
	<p>Use safety Glasses to Avoid Eye Injury Benutzen Sie eine Sicherheitsbrille um Ihre Augen zu schützen Utilisez des lunettes de sécurité pour éviter une blessure aux yeux Usare gli occhiali di sicurezza per evitare il rischio di ferite agli occhi Se deben usar gafas de protección para evitar lesiones de la vista Draag ter voorkoming van oogletsel een veiligheidsbril Använd skyddsglasögon för att undvika ögonskador Χρησιμοποιείτε προστατευτικά γυαλιά για να μην τραυματίσετε τα μάτια σας Utilize óculos de proteção para evitar lesões nos olhos</p>		

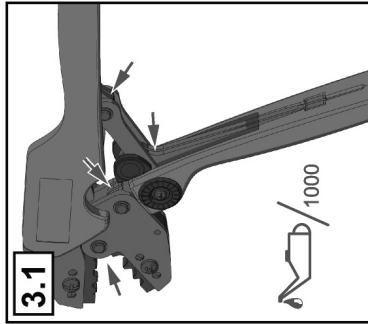

3.1

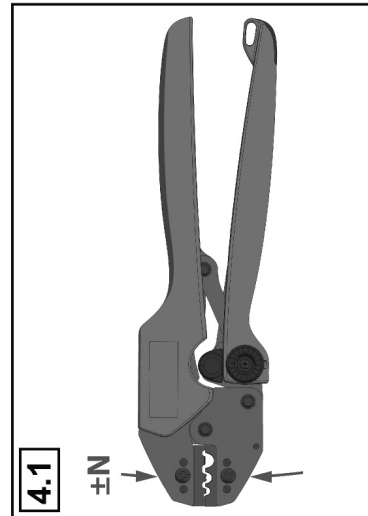

4.1

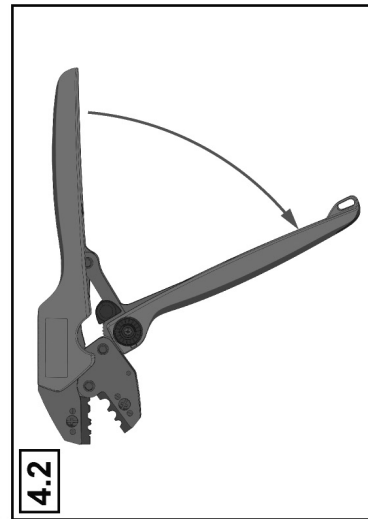

4.2

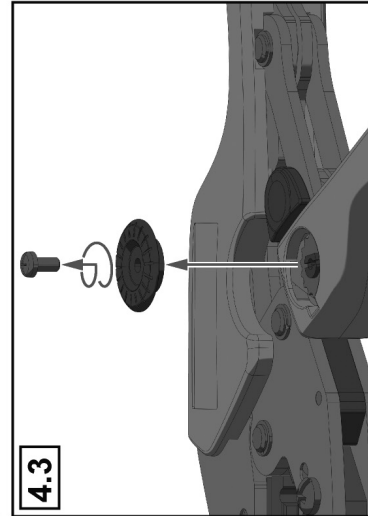

4.3

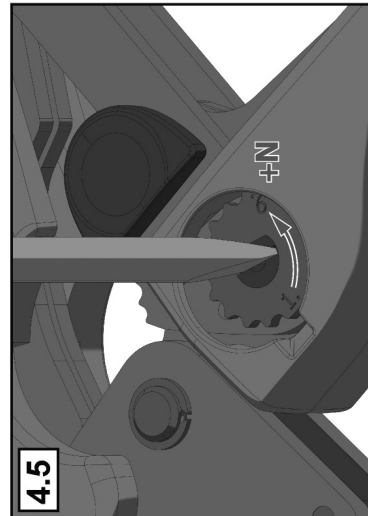

4.5

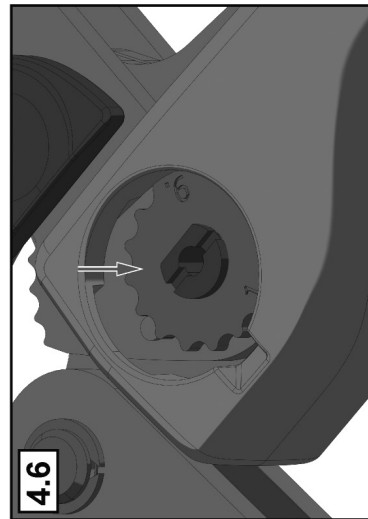

4.6

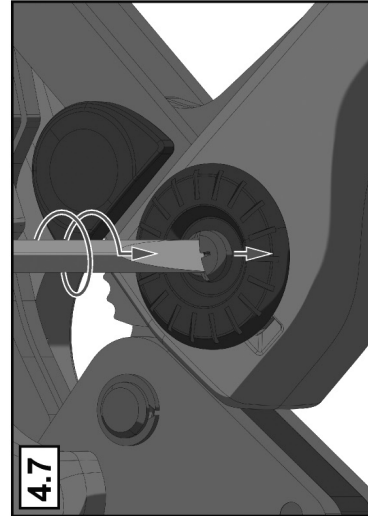

4.7

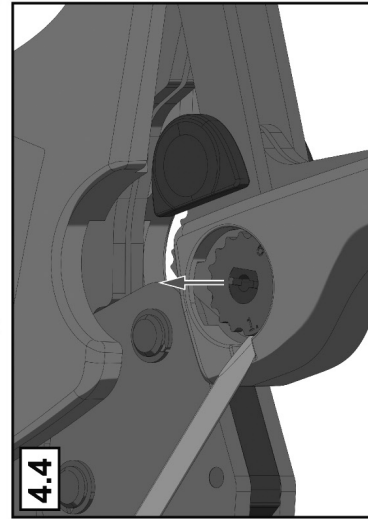

4.4

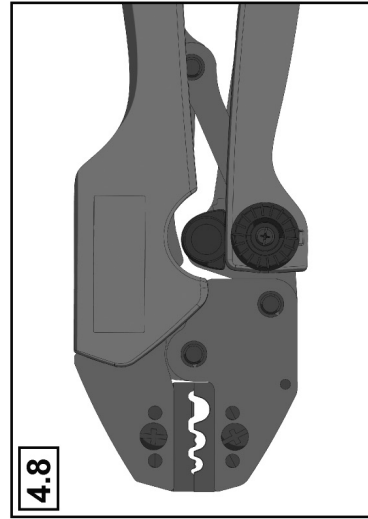

4.8